

*Ambhaze*TM

User Manual

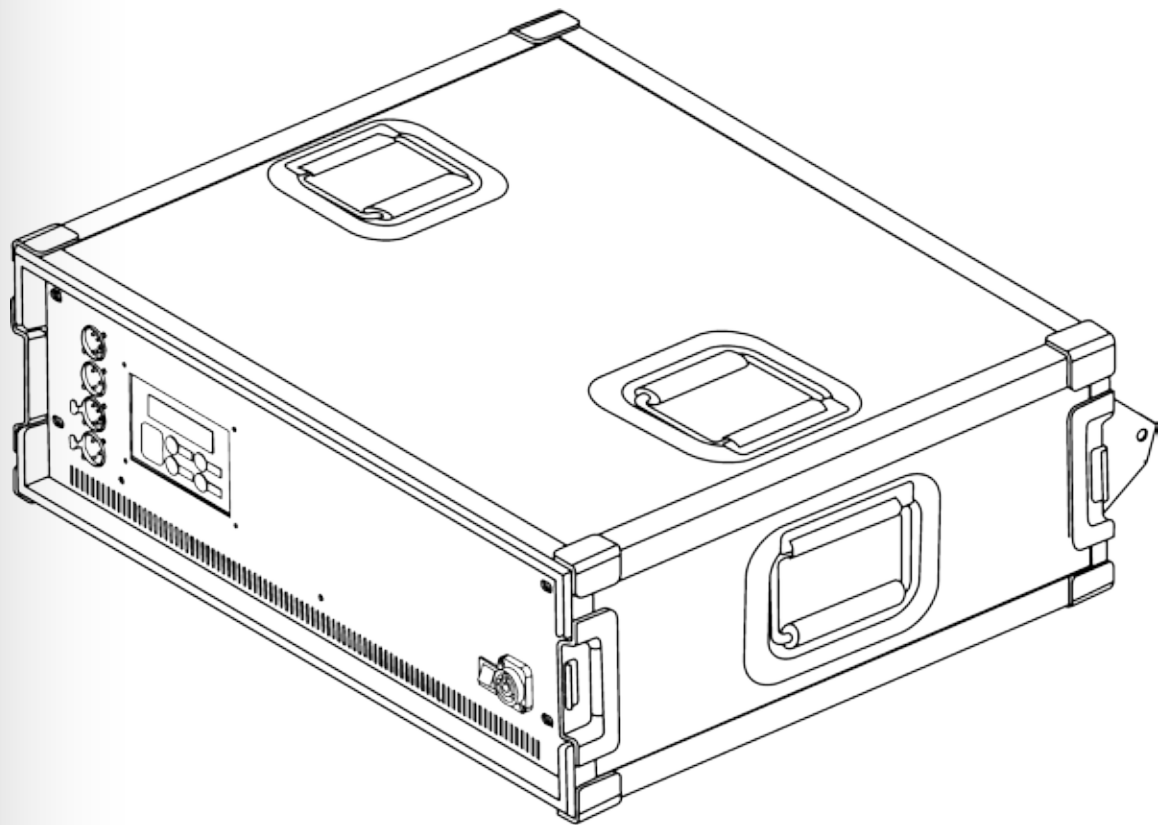

CHAUVET[®]

Edition Notes

The Amhaze™ User Manual Rev. 04 covers the description, safety precautions, installation, programming, operation, and maintenance of the Amhaze™. CHAUVET® released this edition of the Amhaze™ User Manual in November 2011.

Trademarks

CHAUVET® is a registered trademark of CHAUVET & Sons Inc. (d/b/a CHAUVET® or CHAUVET). The CHAUVET® logo in its entirety including the CHAUVET name and the dotted triangle, and all other trademarks on this manual pertaining to services, products, or marketing statements (example: It's Green Thinking™) are owned or licensed by CHAUVET®. Any other product names, logos, brands, company names, and other trademarks featured or referred to within this document are the property of their respective trademark holders.

Copyright Notice

CHAUVET® owns the content of this user manual in its entirety, including but not limited to pictures, logos, trademarks, and resources.

© **Copyright 2011 CHAUVET®. All rights reserved.**

Electronically published by CHAUVET® in the United States of America.

Manual Usage

CHAUVET® authorizes its customers to download and print this manual for professional information purposes only. CHAUVET® expressly prohibits the usage, copy, storage, distribution, modification, or printing of this manual or its content for any other purpose without its written consent.

Document Printing

For better results, print this document in color, on letter size paper (8.5 x 11 inches), double sided. If using A4 paper (210 x 297 mm), configure your printer to scale the content accordingly.

Intended Audience

Any person in charge of installing, operating, and/or maintaining this product should read the guide that shipped with it as well as this manual in their entirety before installing, operating, or maintaining this product.

Disclaimer

CHAUVET® believes that the information contained in this manual is accurate in all respects. However, CHAUVET® assumes no responsibility for any error or omissions in this document. CHAUVET® reserves the right to revise this document and to make changes from time to time in the content hereof without obligation of CHAUVET® to notify any person or company of such revision or changes. This does not constitute in any way a commitment by CHAUVET® to make such changes. CHAUVET® may issue a revision of this manual or a new edition of it to incorporate such changes.

Document Revision

The Amhaze™ User Manual Rev. 04 supersedes all previous versions of this manual. Please discard any older versions of this manual you may have, whether in printed or electronic format, and replace them with this version.

Author	Date	Editor	Date
D. Coupe	11/16/11	M. Graham	11/22/11

Table of Contents

1. Before You Begin	1
What Is Included	1
Unpacking Instructions.....	1
Claims	1
Typographic Conventions	1
Icon Meaning.....	1
Product at a Glance	1
Safety Notes.....	2
2. Introduction	3
Product Description.....	3
Features	3
Additional Features.....	3
Product Overview.....	4
3. Setup	5
AC Power	5
AC Plug	5
Resetting the Breaker.....	5
DMX Linking.....	6
DMX Mode.....	6
Mounting	6
Orientation.....	6
Rigging	6
4. Operation	7
Preparation.....	7
Control Panel Description	7
Startup.....	8
Timer Operation	8
Continuous Operation	8
Programming.....	9
Timer Mode Parameters.....	9
Continuous Mode Parameters	9
DMX Address	9
DMX Values	9
2-Channel Mode.....	9
Menu Map	10
5. Technical Information	11
Hazer Maintenance	11
Storage.....	11
Troubleshooting Guide.....	12
Returns Procedure	13
Claims	13
Contact Us	13
Technical Specifications	14

1. Before You Begin

What Is Included

- One Amhaze™ with Flight Case
- One Power Cord (2 M)
- One Fluid Tank (5 Liter)
- One Warranty Card
- One User Manual

Unpacking Instructions

Immediately upon receiving this product, carefully unpack and check the container. Make sure you have received all the parts indicated above and all the parts are in good condition.

Claims

If the container or the material inside the container (the product and included accessories) appear damaged from shipping, or show signs of mishandling, upon receipt notify the carrier immediately, not CHAUVET®. Failure to notify the carrier in a timely manner may invalidate your claim. In addition, keep the container and all the packing material for inspection.

For other issues such as missing components or parts, damage not related to shipping, or concealed damage, file a claim with CHAUVET® within seven (7) days of receiving the merchandise.

Refer to the [Contact Us](#) section in this manual for addresses and phone numbers.

Typographic Conventions

Convention	Meaning
1~512	A range of values in the text
50/60	A set of mutually exclusive values in the text
Claims	A new term, or a section or chapter in this document
<SET>	A button on the product's control panel
Settings	A product function or a menu option
MENU > Settings	A sequence of menu options
1~10	A range of menu values from which to choose in a menu
Yes/No	A set of two mutually exclusive menu options in a menu
ON	A unique value to be entered or selected in a menu

Icon Meaning

Icon	Meaning
	This icon indicates critical installation, configuration, or operation information. Failure to comply with this information may render the product partially or completely inoperative, damage third-party equipment, or cause harm to the user.
	This icon indicates important installation or configuration information. Failure to comply with this information may prevent the product from functioning correctly.
	This icon indicates useful, although non-critical information.



The term “DMX” used throughout this document refers to the USITT DMX512-A transmission protocol.

Product at a Glance

Use on Dimmer	X	Auto Programs	X
Outdoor Use	X	Auto-ranging Power Supply	X
Sound Activated	X	Resettable Breaker	P
DMX	P	User Serviceable	X
Master/Slave	X	Duty Cycle	X

Safety Notes

There is risk of burns or electric shock while operating this product.

Read all the following Safety Notes before working with this product. These Notes include important information about the installation, usage, and maintenance of this product.



There are no user serviceable parts in this product. Any reference to servicing in this User Manual applies only to properly certified CHAUVET® technicians. Do not open the housing or attempt any repairs unless you are certified.



Please refer to all applicable local codes and regulations for the proper installation of this product.

Personal Safety

- ALWAYS disconnect this product from its power source before cleaning.
- ALWAYS connect this product to a grounded circuit to avoid the risk of electrocution.
- DO NOT touch the output nozzle on this product. It is very hot during operation and it may remain hot for several hours after turning the unit off.
- DO NOT add any flammable liquid (alcohol, perfume, oil, gasoline, etc.) to the fog liquid.
- DO NOT drink the fog liquid. If ingested, call a doctor at once.
- DO NOT allow the fog liquid to touch your skin or eyes. Rinse affected area with plenty of water and call a doctor.

Mounting and Rigging

- DO NOT install this product where it may be exposed to rain or moisture.
- DO NOT hang this product.
- DO NOT mount this product on a flammable surface (e.g., wood, linoleum, carton, plastic, or carpet).
- ALWAYS install this product in a location with adequate ventilation, at least 20 in (50 cm) from adjacent surfaces.
- ALWAYS make sure that there are no flammable materials close to the unit while operating.
- ALWAYS use the handles to carry this product.

Power and Wiring

- NEVER connect this product to a dimmer pack or rheostat.
- NEVER disconnect this product by pulling or tugging on the power cable.
- ALWAYS make sure that you are connecting this product to the proper voltage, as per the specifications in this manual or on the product's sticker.

Operation

- DO NOT operate this product if you see damage on the housing, fluid tank, or cables. In any of these cases, have the damaged parts replaced by an authorized technician at once.
- DO NOT cover the ventilation slots when this product is operating to avoid internal overheating.
- ALWAYS empty this product before storing or transporting it.
- The maximum ambient temperature (Ta) is 104° F (40° C). DO NOT operate this product at a higher temperature.
- In case of a serious operating problem, stop using this product immediately!
- Depending on the amount of fog/haze generated, all fog machines may set off smoke detectors.



In the unlikely event that your CHAUVET® product may require service, please contact CHAUVET® Technical Support.

2. Introduction

Product Description

The Amhaze™ is a professional, water-based, DMX controllable haze machine that provides continuous output with various degrees of density.

It consists of a chassis that contains the pump, fan, power supply, DMX connections, and control panel. It comes installed in a stackable flight case that also provides room to keep the fluid tank during operation.

Features

- Operating mode:
 - 2-channel: Output volume, fan speed
- Continuous output
- Haze output and fan speed controllable locally or via DMX
- Stackable flight case
- Onboard system timer
- Resettable circuit breaker
- Silent operation

Additional Features

- Neutrik® powerCON® A connector
- 3- and 5-pin DMX input and output connectors
- LCD display

Product Overview

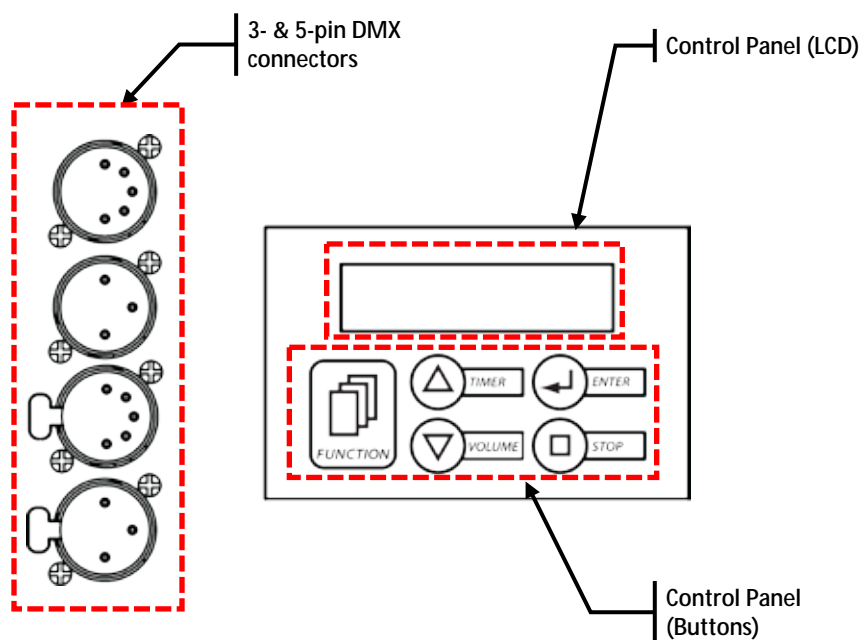
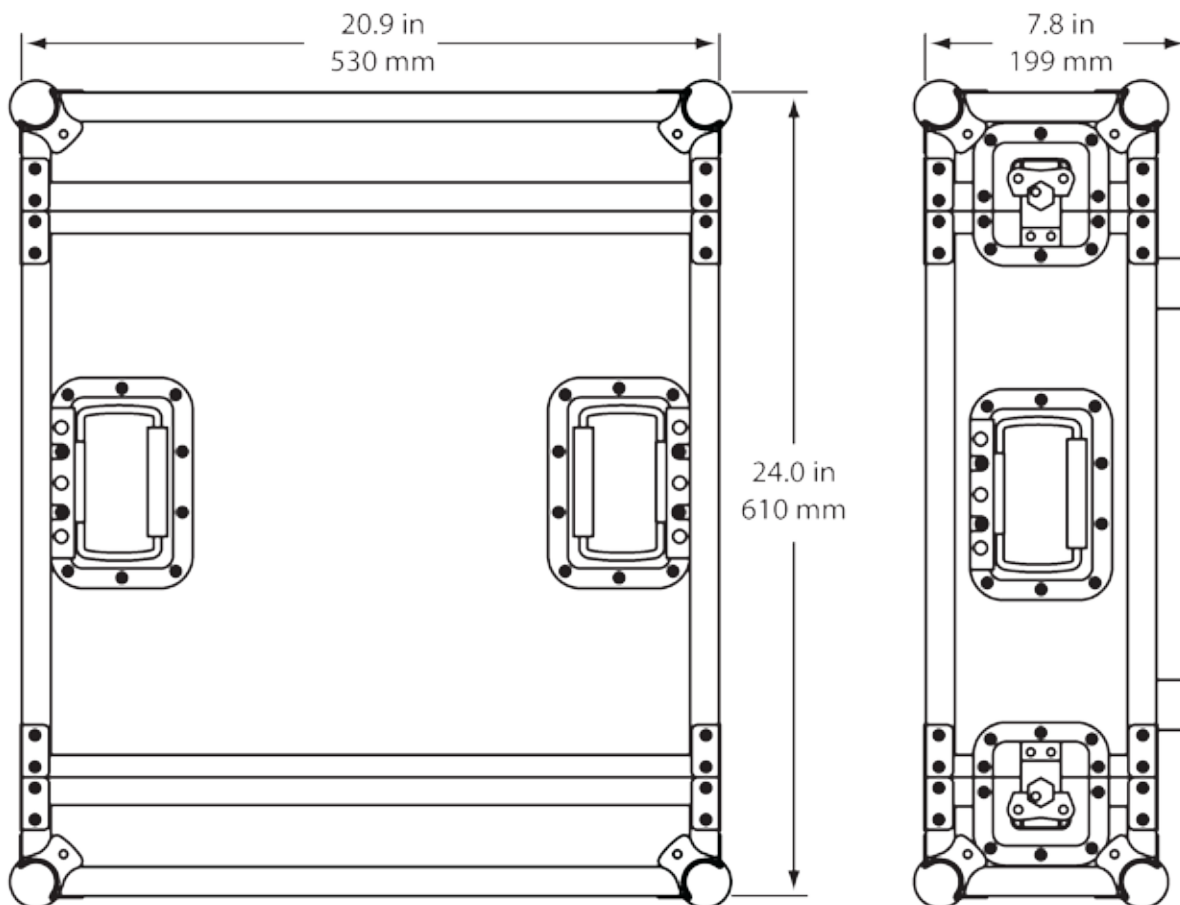

3. Setup

AC Power

This product comes in two models, each with a fixed input voltage power supplies, either 120 V, 60 Hz or 230 V, 50 Hz. Therefore, you have to order the correct model for the line voltage in your area.

Make sure that you are connecting this product to the proper voltage, as per the specifications in this guide or on the product's sticker.



Always connect this product to a protected circuit with an appropriate electrical ground to avoid the risk of electrocution or fire.

The listed current rating indicates the maximum current draw during normal operation. For more information, download the document *Sizing the Circuit Breakers* from the CHAUVET® website: www.chauvetpro.com.



Never connect this product to a rheostat (variable resistor) or dimmer circuit, even if the rheostat or dimmer channel serves only as a 0 to 100% switch.

AC Plug

The Amhaze™ comes with a power input cord terminated with a Neutrik® powerCON® A connector on one end an Edison plug on the other end (US market). If the power input cord that came with your product has no plug or you need to change the plug, use the table below to wire the new plug.

Connection	Wire (US)	Wire (Europe)	Screw Color
AC Live	Black	Brown	Yellow or Brass
AC Neutral	White	Blue	Silver
AC Ground	Green/Yellow	Green/Yellow	Green



Resetting the Breaker

Disconnect this product from the power outlet before resetting the breaker.

This product is equipped with a resettable circuit breaker on the power input circuit. If the breaker trips, all sections of this product will lose power. Please see the instructions below for resetting this breaker.

1. Remove the power cord from mains power.
2. Allow unit to cool for 15 minutes.
3. After 15 minutes, you may attempt to reset the breaker by pressing the button with your index finger.
4. Plug the product's power cord into the power outlet and continue using as recommended.



If the breaker does not reset (the breaker button will not remain inserted), contact CHAUVET® immediately, as this indicates a possible internal malfunction.

- DMX Linking** You may link the Amhaze™ to a DMX controller using a standard DMX serial connection. If using other DMX compatible units with this product, it is possible to control them individually with a single DMX controller.
- DMX Mode** The Amhaze™ uses the standard DMX data connection for the 2-Channel DMX mode. Refer to the [Introduction](#) chapter for a brief description of this mode. Refer to the [Operation](#) chapter to learn how to configure the Amhaze™ to work in this mode. The [DMX Values](#) section will provide you with detailed information regarding the DMX modes.
- Mounting** Before mounting this product, read and follow the [Safety Notes](#) in this manual.
- Orientation** Always mount this product in any safe position while making sure that there is adequate room around it for ventilation, configuration, and maintenance.
- Rigging** CHAUVET® recommends following the general guidelines below when mounting this product.
- When selecting an operation location, consider ease of access to this product for operation, programming adjustments, and routine maintenance as well as the vicinity to a suitable power outlet.
 - Make sure to mount this product away from any flammable material as indicated in the *Safety Notes* section.
 - Never mount the product in places where rain, high humidity, extreme temperature changes, or restricted ventilation may affect it.
 - Never mount this product on a flammable or heat sensitive surface, such as carpet, linoleum, wood, paper, carton, or plastic.
 - Never hang this product.
 - Make sure that the place on which you mount this product can safely support its weight without vibrations. See the Technical Specifications for weight and size details.
- Procedure** The Amhaze™ comes in a stackable flight case. You only need to find a suitable place to set it up. Follow the instructions in the [Preparation](#) section to setup the Amhaze™ once properly located.

4. Operation

Preparation

Once installed, you have to prepare the Amhaze™ for operation. To do so, follow these steps:

1. Open both ends of the flight case.
2. Pull out the fluid tank.
3. Remove the cap of the fluid tank.
4. Verify that the two plastic hoses attached to the cap are in place and in good condition.
5. Pour Chauvet (PHF) haze fluid inside the tank.
6. Replace the cap of the fluid tank making sure that is tightly closed
7. Reinsert the tank.
8. Make sure that the plastic hose that goes from the cap to the hazer is not bent.
9. To direct the haze up or down, pull the haze guide from the front panel and install it in the desired position.



Only use CHAUVET® approved (PHF) haze fluid. Otherwise, you might not have satisfactory results. In addition, the unapproved fluid can damage the Amhaze™, or cause harm to humans or animals.

Control Panel Description

Before using the Amhaze™, you should become familiar to the control panel.

The table and diagram below will provide you with a description of its buttons and functions.

Button	Function
<FUNCTION>	Enters the programming mode
<VOLUME>	Controls the haze pump to modify the output volume
<TIMER>	Starts the timer controlled operation
<STOP>	Stops the current operation, whether manual or timer controlled
<ENTER>	Enables the currently displayed menu or sets the currently selected value in to the current function
<UP>	Navigates upward through the menu list and increases the numeric value when in a function
<DOWN>	Navigates downward through the menu list and decreases the numeric value when in a function

Control Panel Diagram

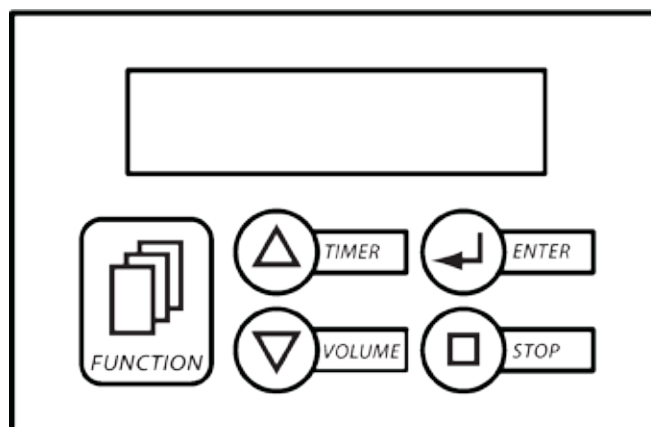

Startup

The Amhaze™ does not have an On/Off switch. As soon as you connect the Amhaze™ to the power outlet, it will start operating.

To start up the Amhaze™, do the following:

1. Insert the Neutrik® powerCON® A connector of the power input cord into the lockable (blue) socket on the back of the Amhaze™.
2. Turn the connector right until it locks in position.
3. Plug the power input cords to a suitable power outlet (the display will show “**Warm Up Cycle**”).
4. Wait about two minutes for the warm-up to complete. During this time, the Amhaze™ will not produce any haze.
5. After warming up, the display will show “**READY TO HAZE FLUID SENSOR ON/OFF**”.
6. Press **<VOLUME>**.
7. Adjust haze output volume by using the **<UP>** or **<DOWN>**.
8. Press **<STOP>** again to stop haze production.



Repeat the Startup procedure after transporting the Amhaze™ or after a fluid refill.

Timer Operation

When in Timer mode, the Amhaze™ will produce haze in pre-configured time intervals defined by the TIME INTERVAL and TIME DURATION menu options. In addition, the output volume during Timer mode is set by the TIMER VOLUME menu option. See the [Programming](#) section for details about how to configure these parameters.

To operate in Timer mode, do the following:

1. Press **<TIMER>** (the display will show a countdown of the Interval Timer).
2. When the counter reaches zero (0), the Amhaze™ will start producing haze.
3. The hazing duration is set by the TIMER DURATION menu option.
4. The hazing volume during Timer mode is set by the TIMER VOLUME menu option.
5. This cycle will repeat itself until you press **<STOP>** again or until the Amhaze™ runs out of fluid.



The Amhaze™ can produce continuous haze without reheating. This means that hazing will start immediately each time the Interval timer reaches zero (0).

Continuous Operation

In the Continuous mode, the Amhaze™ will produce haze without interruptions. The output volume is set in the VOLUME MODE OUT menu option. See the *Programming* section for details about how to configure this parameter.

To operate in Continuous mode, do the following:

1. Press **<VOLUME>** (the display will show “**VOLUME MODE OUT**” and the percentage of the output volume).
2. This mode will continue itself until you press **<STOP>** or until the Amhaze™ runs out of fuel.



The Amhaze™ can produce continuous haze without reheating. This means that hazing will start immediately each time you press <VOLUME>.

Programming

The Programming mode allows you to change the options that affect the various operating modes as well as setting the DMX address.

Timer Mode Parameters

These parameters determine the on and off intervals as well as the output volume when the Amhaze™ is in Timer mode.

To configure these parameters do the following:

1. Press **<FUNCTION>** repeatedly until **"TIME INTERVAL"** shows on the display.
2. Use **<UP>** or **<Down>** to set the time off timer (1~200 s).
3. Press **<FUNCTION>** repeatedly until **"TIME DURATION"** shows on the display.
4. Use **<UP>** or **<Down>** to set the time on (1~200 s).
5. Press **<FUNCTION>** repeatedly until **"TIMER VOLUME"** shows on the display.
6. Use **<UP>** or **<Down>** to set the haze volume (1~100%).

Continuous Mode Parameters

These parameters affect the haze and fan volumes when the Amhaze™ operates in Continuous mode.

To configure these parameters do the following:

1. Press **<FUNCTION>** repeatedly until **"VOLUME MODE OUT"** shows on the display.
2. Use **<UP>** or **<Down>** to set the haze volume (1~100%).
3. Press **<FUNCTION>** repeatedly until **"VOLUME MODE FAN"** shows on the display.
4. Use **<UP>** or **<Down>** to set the fan volume (1~100%).



During stand-by periods, the fan volume resets to 20% to keep a low noise level.

DMX Address

This parameter determines the DMX starting address of the Amhaze™. Refer to the *DMX Values* section to learn the values and assignments of the AmHaze's 2-channel mode.

The following steps will show you how to configure the DMX starting address.

1. Press **<FUNCTION>** repeatedly until **"DMX ADDRESS"** shows on the display.
2. Use **<UP>** or **<Down>** to set the DMX starting address (001~511).

DMX Values

2-Channel Mode

Channel	Function	Value	Percent/Setting
1	Output Volume	000 ◊ 005 006 ◊ 255	No output 2~100%
2	Fan Volume	000 ◊ 255	20~100%

Menu Map

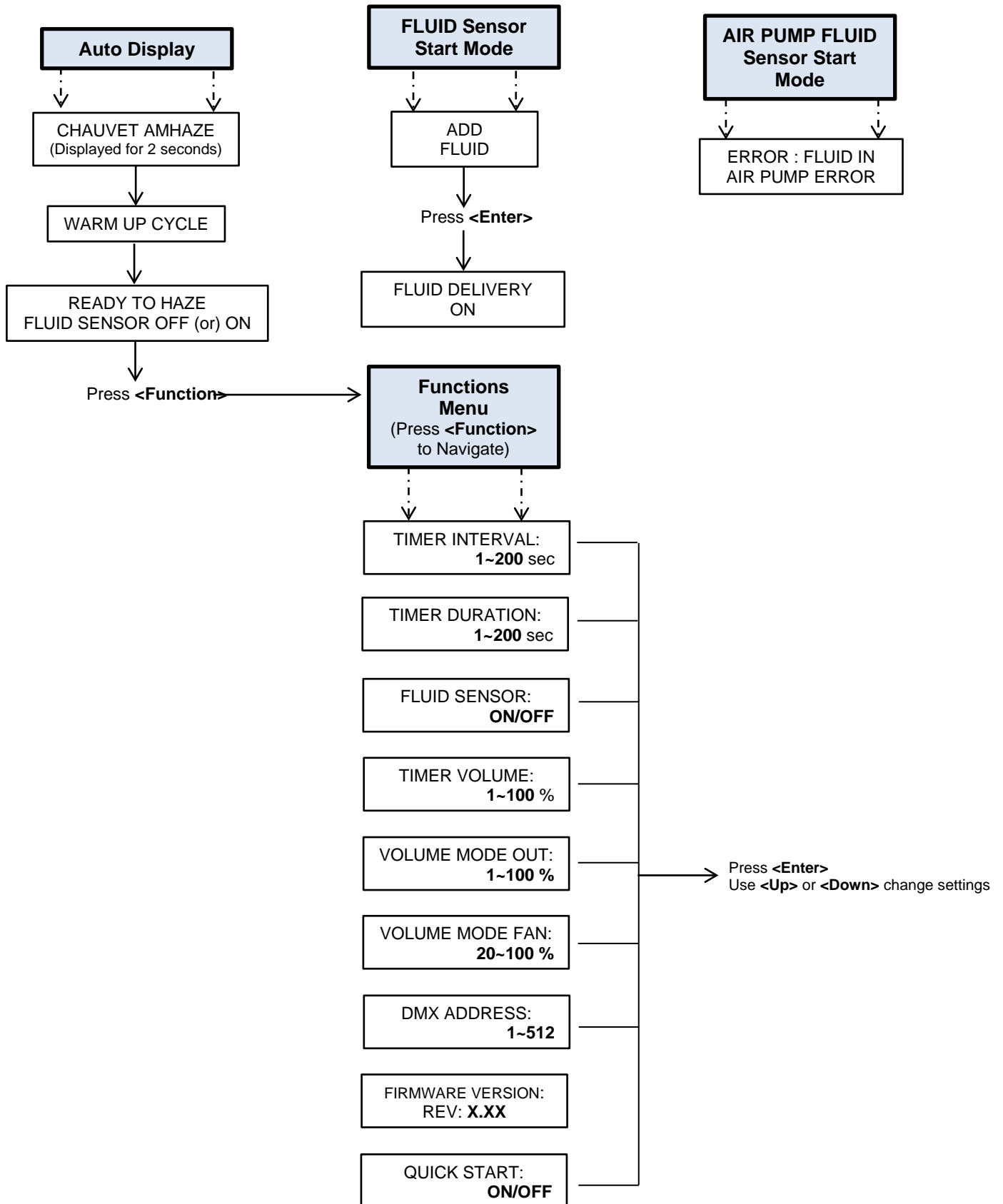

5. Technical Information

Hazer Maintenance

Do not allow the hazer to become contaminated. After 40 hours of continuous operation, it is recommended to run a cleaning solution composed of 80% distilled water and 20% distilled vinegar through the system to prevent the accumulation of particulate matter in the heating element.

The recommended cleaning routine is as follows:

1. Empty all fog liquid from the machine.
2. Add cleaning solution to tank.
3. Plug unit in and allow it to warm up.
4. Run the unit in a well-ventilated area until the tank is almost empty.
5. Do not allow the pump to run dry.
6. Cleaning is now complete.

Before operating the hazer after cleaning it, do the following:

1. Refill with fog liquid.
2. Run the machine briefly to clear any cleaning solution from the pump and heater.



Refrain from spinning this product's fan(s) using compressed air.

Storage

Before storing this product, run distilled water (not tap water) through the system as described in the cleaning method above. This will help to avoid any particles condensing inside the pump or heater.

It is strongly recommended to test-run the machine on a monthly basis in order to achieve its best hazing condition.



NEVER operate the hazer without fluid at any time.

Troubleshooting Guide

Symptom	Cause(s)	Action(s)
Unit powers up but it generates no haze	Hazer is still cold Wrong fluid Lack of fluid Faulty pump	Wait until hazer is ready to operate Clean the hazer and use approved fluid Follow the fluid replenishment procedure Send unit for repair
Haze comes out but it is too thick/thin	Erroneous haze volume adjustment Wrong fluid Faulty pump	Adjust haze volume as explained Clean the hazer and use approved fluid Send unit for repair
Circuit breaker/fuse keeps tripping/blowing	Excessive circuit load Short circuit along the power wires	Reduce total load placed on the electrical circuit Check electrical wiring
Unit does not power up	No power Loose or damaged power cord Built-in breaker tripped Faulty internal power supply	Check for voltage on outlet Check power cord Follow instruction to reset the breaker Send unit for repair
Unit does not respond to wired DMX or responds erratically	Wrong DMX addressing Damaged DMX cables Wrong polarity on the controller Loose DMX cables Non DMX cables Bouncing signals Long cable / low level signal Too many units Interference from AC wires Faulty DMX interface Faulty Main board	Check unit addressing Check DMX cables Check polarity switch settings on the controller Check cable connections Use only DMX compatible cables Install terminator as suggested Install an optically coupled DMX splitter before a long section of cable or right after the unit with the strong signal Install an optically coupled DMX splitter after unit #32 Keep DMX cables separated from power cables or fluorescent/black lights Send unit for repair Send unit for repair



If you still experience technical problems after trying the above solutions or if you need to send the unit for repair, contact CHAUVET® Technical Support.

Returns Procedure

The user must send the merchandise prepaid, in the original box, and with its original packing and accessories. CHAUVET® will not issue call tags.

Call CHAUVET® and request a Return Merchandise Authorization (RMA) number before shipping the unit. Be prepared to provide the model number, serial number, and a brief description of the cause for the return.

The user must clearly label the package with a Return Merchandise Authorization (RMA) number. CHAUVET® will refuse any product returned without an RMA number.



DO NOT write the RMA number directly on the box. Instead, write it on a properly affixed label.

Once you have received the RMA number please include the following information on a piece of paper inside the box:

- Your name
- Your address
- Your phone number
- The RMA number
- A brief description of the problem

Be sure to pack the unit properly. Any shipping damage resulting from inadequate packaging will be the customer's responsibility. As a suggestion, proper UPS packing or double-boxing is always a safe method to use.



CHAUVET® reserves the right to use its own discretion to repair or replace returned product(s).

Claims

The carrier is responsible for any damage incurred during shipping to this product or any part that shipped with it. Therefore, if the received merchandise appears to have damages caused during shipping, the customer must submit the damage report and any related claims with the carrier, not CHAUVET®. The customer must submit the report upon reception of the damaged merchandise. Failure to do so in a timely manner may invalidate the customer's claim with the carrier.

For other issues such as missing components or parts, damage not related to shipping, or concealed damage, the customer must make claims to CHAUVET® within seven (7) days of receiving the merchandise.

Contact Us

World Headquarters

CHAUVET®

General Information

Address: 5200 NW 108th Avenue
Sunrise, FL 33351
Voice: (954) 929-1115
Fax: (954) 929-5560
Toll free: (800) 762-1084

Technical Support

Voice: (954) 929-1115 (Press 4)
Fax: (954) 756-8015
Email: tech@chauvetlighting.com

World Wide Web

www.chauvetlighting.com

United Kingdom & Ireland

CHAUVET® Europe Ltd.

General Information

Address: Unit 1C
Brookhill Road Industrial Estate
Pinxton, Nottingham, UK
NG16 6NT
Voice: +44 (0)1773 511115
Fax: +44 (0)1773 511110

Technical Support

Email: uktech@chauvetlighting.com

World Wide Web

www.chauvetlighting.co.uk

Technical Specifications

Dimensions and Weight	Length	Width	Height	Weight
	24 in (610 mm)	20.9 in (530mm)	7.8 in (199 mm)	46.3 lbs (21 kg)

Note: Dimensions in inches rounded to the nearest decimal digit.

Electrical	Power Supply Type	Range	Voltage Selection
	Conventional (transformer)	120 V, 60 Hz or 230 V, 50 Hz	Fixed voltage models

Parameter	120 V, 60 Hz	240 V, 50 Hz
Consumption	830 W	900 W
Operating current	6.95 A	3.75 A
Circuit breaker	10 A	5 A

Power I/O	US/Worldwide	Europe
Power input connector	Neutrik® powerCON® A	Neutrik® powerCON® A
Power Cord plug	Edison (US)	Local plug

Haze Production	Parameter	Value
	First heating-up time (cold hazer)	4 minutes
	Heater temperature (after warm-up cycle completed)	446° F (230° C)
	Fluid consumption (at 100% output)	4.7 ml per minute
	Approved fluid	PHF
	Tank capacity	5 liters
	Output	3,000 cfm

Thermal	Max. External Temperature	Cooling System
	104° F (40° C)	Fan

DMX	I/O Connectors	Connector Type	Channel Range
	3- and 5-pin XLR	Sockets	2

Ordering	Product Name	Item Code	Item Number
	Amhaze™ (120 V, 50/60 Hz)	99070313	AMHAZE
	Amhaze™ (240 V, 50/60 Hz)	99070316	220VAMHAZE
	Amhaze™ PHF - Premium Haze Fluid	14070461	PHF



CHAUVET®
5200 NW 108th Avenue
Sunrise, FL 33351 (USA)
(800) 762-1084 – (954) 929-1115
FAX (954) 929-5560
www.chauvetlighting.com

Amhaze™ User Manual Rev. 04
November 2011

